

34 Triangle XYZ is shown below. Using a compass and straightedge, on the line below, construct and label $\triangle ABC$, such that $\triangle ABC \cong \triangle XYZ$. [Leave all construction marks.]

Based on your construction, state the theorem that justifies why $\triangle ABC$ is congruent to $\triangle XYZ$.

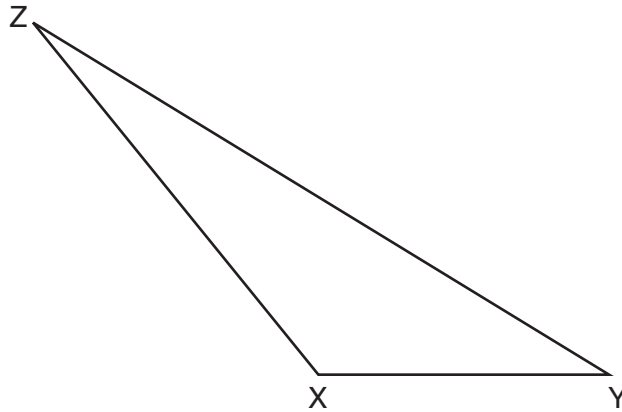

Part IV

Answer the 2 questions in this part. Each correct answer will receive 6 credits. Clearly indicate the necessary steps, including appropriate formula substitutions, diagrams, graphs, charts, etc. Utilize the information provided for each question to determine your answer. Note that diagrams are not necessarily drawn to scale. For all questions in this part, a correct numerical answer with no work shown will receive only 1 credit. All answers should be written in pen, except for graphs and drawings, which should be done in pencil. [12]

35 Given: Parallelogram $ANDR$ with \overline{AW} and \overline{DE} bisecting \overline{NWD} and \overline{REA} at points W and E , respectively

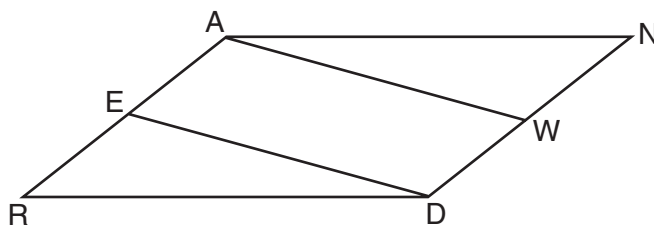

Prove that $\triangle ANW \cong \triangle DRE$.

Prove that quadrilateral $AWDE$ is a parallelogram.

36 Cathy wants to determine the height of the flagpole shown in the diagram below. She uses a survey instrument to measure the angle of elevation to the top of the flagpole, and determines it to be 34.9° . She walks 8 meters closer and determines the new measure of the angle of elevation to be 52.8° . At each measurement, the survey instrument is 1.7 meters above the ground.

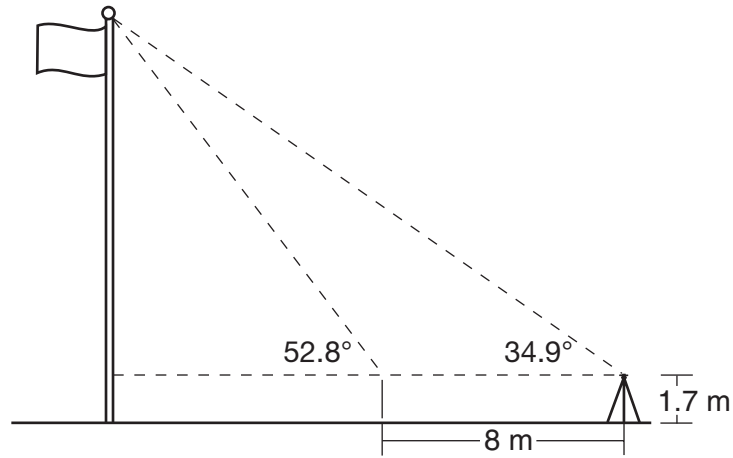

Determine and state, to the *nearest tenth of a meter*, the height of the flagpole.