

- 34 A gas station has a cylindrical fueling tank that holds the gasoline for its pumps, as modeled below. The tank holds a maximum of 20,000 gallons of gasoline and has a length of 34.5 feet.

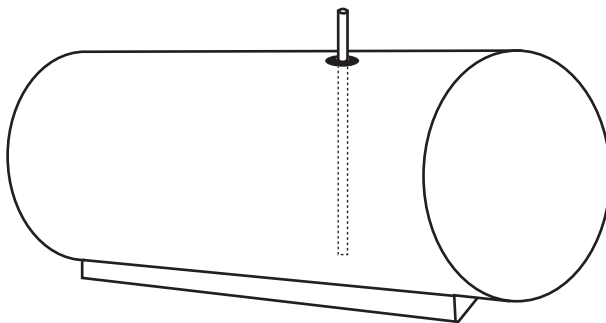

A metal pole is used to measure how much gas is in the tank. To the *nearest tenth of a foot*, how long does the pole need to be in order to reach the bottom of the tank and still extend one foot outside the tank? Justify your answer. [$1 \text{ ft}^3 = 7.48 \text{ gallons}$]

Part IV

Answer the 2 questions in this part. Each correct answer will receive 6 credits. Clearly indicate the necessary steps, including appropriate formula substitutions, diagrams, graphs, charts, etc. Utilize the information provided for each question to determine your answer. Note that diagrams are not necessarily drawn to scale. For all questions in this part, a correct numerical answer with no work shown will receive only 1 credit. All answers should be written in pen, except for graphs and drawings, which should be done in pencil. [12]

35 Quadrilateral $PQRS$ has vertices $P(-2,3)$, $Q(3,8)$, $R(4,1)$, and $S(-1,-4)$.

Prove that $PQRS$ is a rhombus.

[The use of the set of axes on the next page is optional.]

Question 35 is continued on the next page.

Question 35 continued.

Prove that $PQRS$ is *not* a square.
[The use of the set of axes below is optional.]

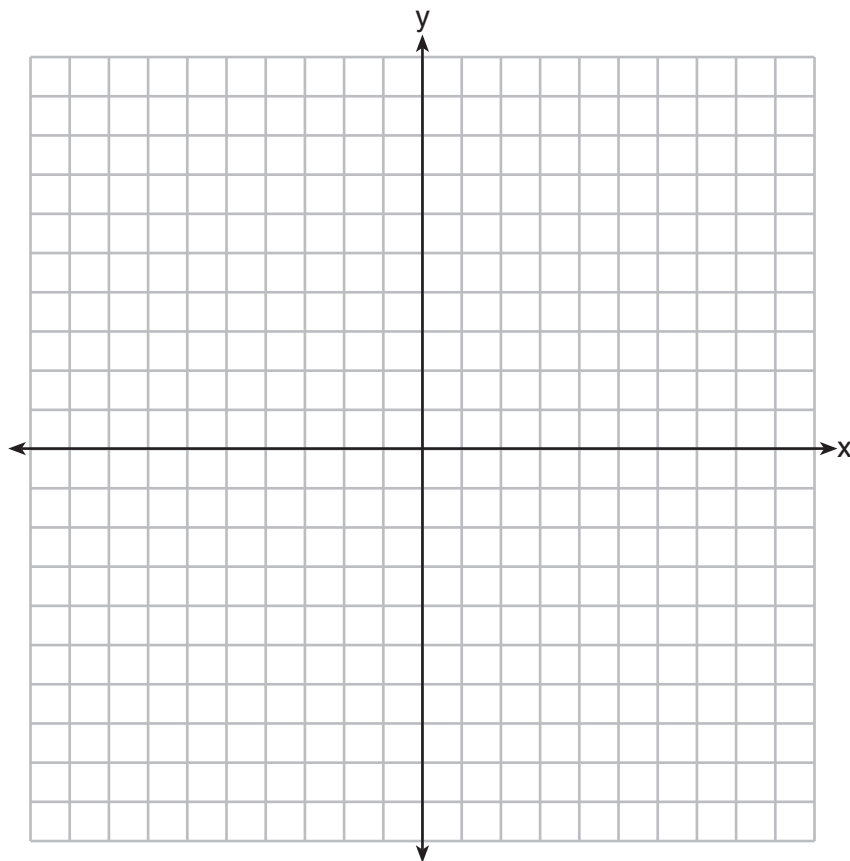

36 Freda, who is training to use a radar system, detects an airplane flying at a constant speed and heading in a straight line to pass directly over her location. She sees the airplane at an angle of elevation of 15° and notes that it is maintaining a constant altitude of 6250 feet. One minute later, she sees the airplane at an angle of elevation of 52° . How far has the airplane traveled, to the nearest foot?

Determine and state the speed of the airplane, to the nearest mile per hour.