

- 33 The map of a campground is shown below. Campsite C , first aid station F , and supply station S lie along a straight path. The path from the supply station to the tower, T , is perpendicular to the path from the supply station to the campsite. The length of path \overline{FS} is 400 feet. The angle formed by path \overline{TF} and path \overline{FS} is 72° . The angle formed by path \overline{TC} and path \overline{CS} is 55° .

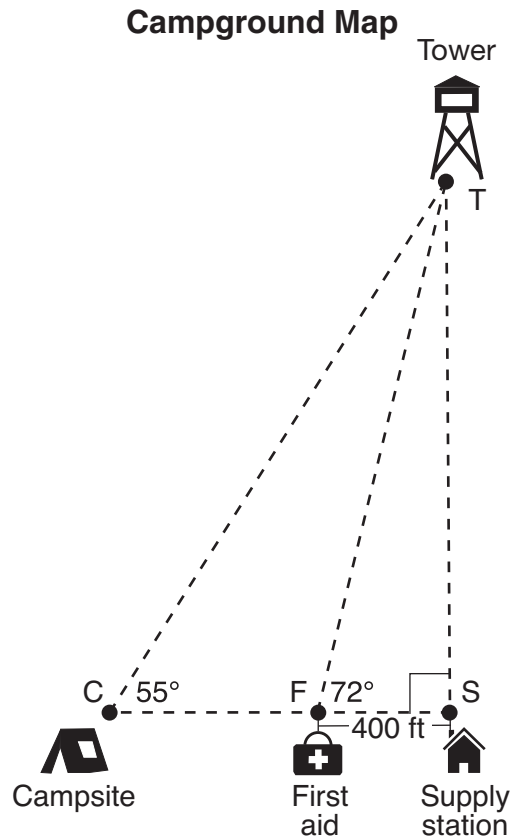

Determine and state, to the *nearest foot*, the distance from the campsite to the tower.

34 Shae has recently begun kickboxing and purchased training equipment as modeled in the diagram below. The total weight of the bag, pole, and unfilled base is 270 pounds. The cylindrical base is 18 inches tall with a diameter of 20 inches. The dry sand used to fill the base weighs 95.46 lbs per cubic foot.

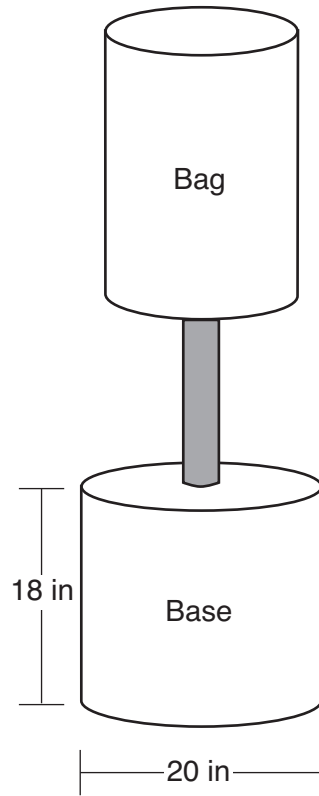

To the *nearest pound*, determine and state the total weight of the training equipment if the base is filled to 85% of its capacity.

Part IV

Answer the question in this part. A correct answer will receive 6 credits. Clearly indicate the necessary steps, including appropriate formula substitutions, diagrams, graphs, charts, etc. Utilize the information provided for the question to determine your answer. Note that diagrams are not necessarily drawn to scale. A correct numerical answer with no work shown will receive only 1 credit. All answers should be written in pen, except for graphs and drawings, which should be done in pencil. [6]

35 Given: Parallelogram $ABCD$, $\overline{BF} \perp \overline{AFD}$, and $\overline{DE} \perp \overline{BEC}$

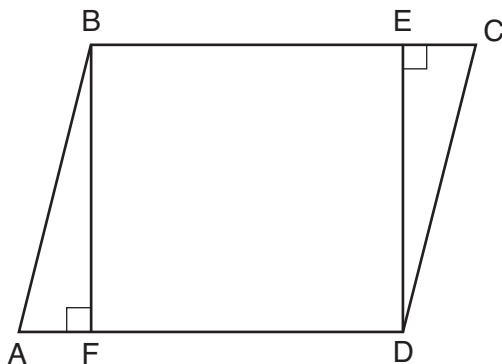

Prove: $BEDF$ is a rectangle

Work space for question 35 is continued on the next page.