



Math

Spring 2018

Geometry

Released Items

1.

VH017425

Figure 1 is a rhombus and Figure 2 is a rectangle. Neither figure is a square.

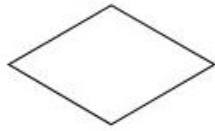

Figure 1



Figure 2

Which transformation can be used to map Figure 1 onto itself and can also be used to map Figure 2 onto itself?

- A. a rotation of 90° clockwise about the center of the figure
- B. a rotation of 180° about the center of the figure
- C. a reflection over a line through the center of the figure that is parallel to one of the sides of the figure
- D. a reflection over one of the diagonals of the figure

2.

VH233587

Quadrilateral $ABCD$ is graphed in a coordinate plane.

Part A

Quadrilateral $ABCD$ will be reflected across the y -axis to produce $A'B'C'D'$. What will be the location of $A'B'C'D'$?

Select the correct orientation of the figure and position it correctly in the plane.

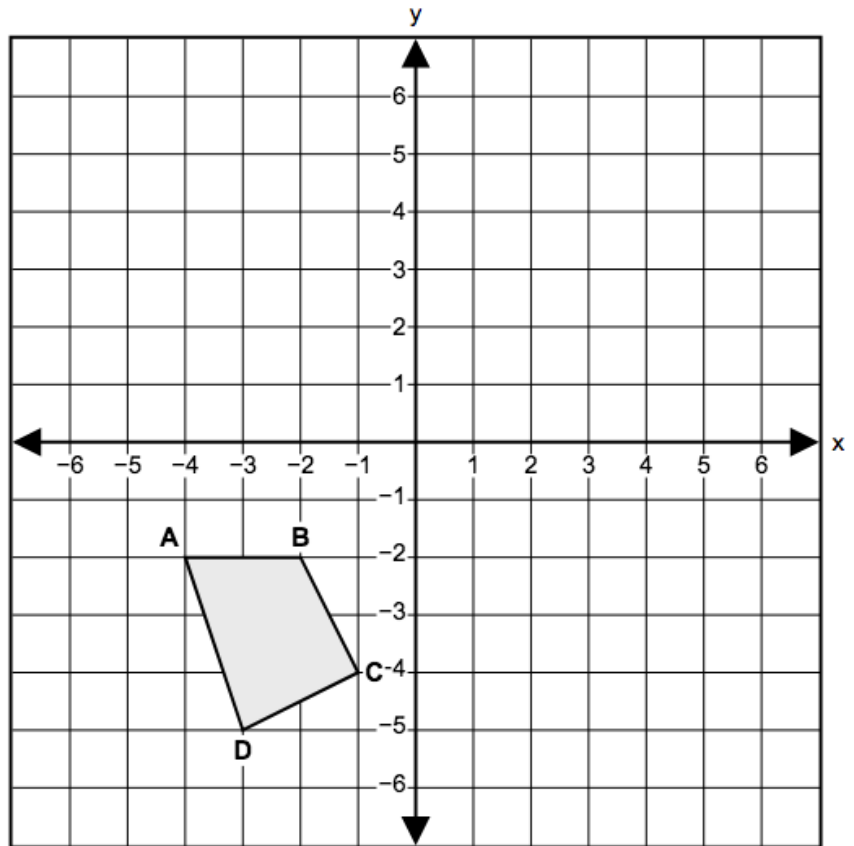
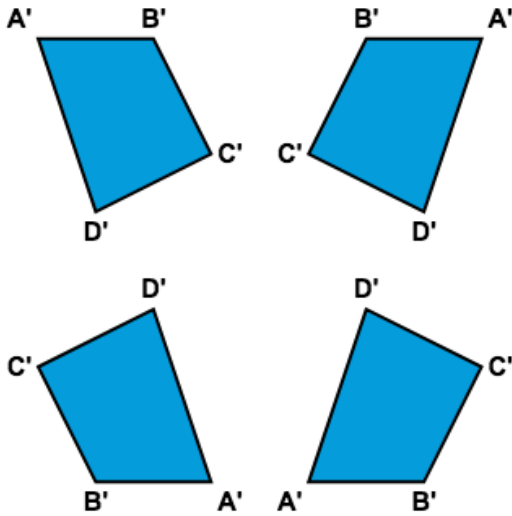

Part B

Quadrilateral $ABCD$ will be reflected across the x -axis to produce $A''B''C''D''$.

Given that (x, y) describes a vertex of $ABCD$, which coordinates describe the corresponding vertex of $A''B''C''D''$?

- A. $(x - 1, y - 1)$
- B. $(-x, -y)$
- C. $(x, -y)$
- D. $(-x, y)$

3.

VF908221

Triangle ABC is dilated with scale factor $\frac{1}{2}$ and center P onto triangle DEF .

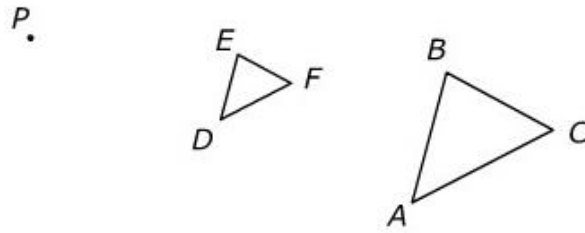

Which statements must be true?

Select **all** that apply.

- A. $\overline{AB} \parallel \overline{DE}$
- B. $m\angle A = m\angle F$
- C. $m\angle B = m\angle E$
- D. The length of segment AC is twice the length of segment DF .
- E. The length of segment EF is twice the length of segment BC .
- F. The distance from P to D is equal to the distance from P to A .
- G. The distance from P to B is twice the distance from P to E .

4.

M42124P

Refer to the diagram.

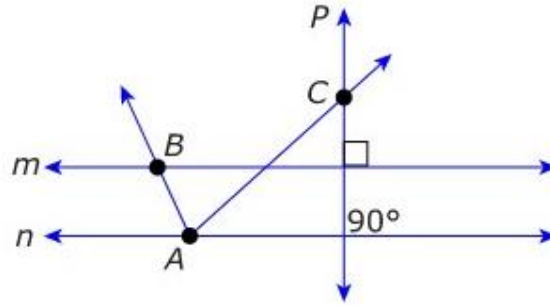

Which terms are demonstrated in the figure?

Select **all** that apply.

- A. circle
- B. angle
- C. skew lines
- D. parallel lines
- E. line segment
- F. perpendicular lines

5.

M47800P

What two-dimensional cross section do a cube and a square pyramid have in common?

Select **all** that apply.

- A. ellipse
- B. hexagon
- C. octagon
- D. square
- E. triangle

6.

M43185

On a coordinate plane, a line segment has endpoints $P(6, 2)$ and $Q(3, 8)$.

Point M lies on \overline{PQ} and divides the segment so that the ratio of $PM:MQ$ is 3:2. What are the coordinates of point M ?

- A. (4.5, 5.0)
- B. (5.6, 4.2)
- C. (4.8, 4.4)
- D. (4.2, 5.6)

7.

VH152895

Consider the three transformations described:

- Triangle ABC is the image of $\triangle XYZ$ after a reflection across \overline{XY} .
- Triangle DEF is the image of $\triangle XYZ$ after a rotation of 180° about point X .
- Triangle GHJ is the image of $\triangle XYZ$ after a dilation of scale factor $\frac{2}{3}$ centered at point X .

Determine whether each statement is true or false.

Select the boxes to identify whether each statement is true or false.

Statement	True	False
$\triangle ABC \cong \triangle XYZ$	<input type="radio"/>	<input type="radio"/>
$\triangle DEF \cong \triangle XYZ$	<input type="radio"/>	<input type="radio"/>
$\triangle GHJ \cong \triangle XYZ$	<input type="radio"/>	<input type="radio"/>

8.

M40060P

The graph shows $\triangle ABC$ and $\triangle A'B'C'$.

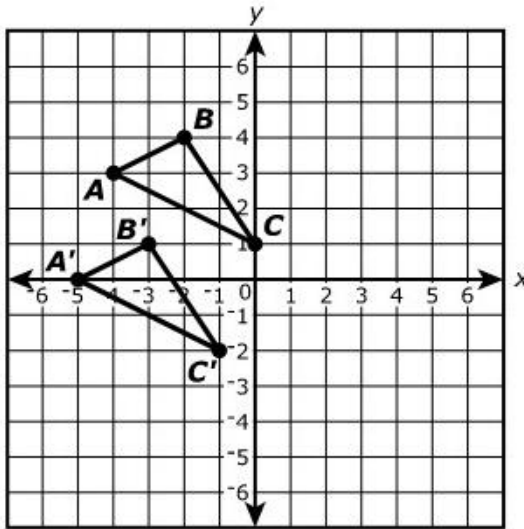

Which sequence of transformations will carry $\triangle ABC$ onto $\triangle A'B'C'$?

- A. translation left 3 units and translation up 1 unit
- B. translation left 1 unit and translation down 3 units
- C. 180° clockwise rotation about the origin and a reflection about the y -axis
- D. 180° clockwise rotation about the origin and a reflection about the $y = x$ line

9.

VH034586

Segment AB has endpoints $A(-2, 8)$ and $B(4, 0)$. The segment is dilated about the origin by a scale factor of 0.5 to create segment $A'B'$.

What are the endpoints of segment $A'B'$?

Select **both** endpoints.

- A. $(-2, 8)$
- B. $(-1, 4)$
- C. $(0, 0)$
- D. $(1, 4)$
- E. $(2, 0)$
- F. $(4, 0)$

10.

VH237320

Circle P is graphed in the coordinate plane with center $(2, 3)$. Circle P contains the point $(4, 6)$.

Part A

What is an equation of circle P ?

Enter your equation in the space provided. Enter **only** your equation.

↶	+	-	×	÷	□	□
↷	y^x	$\sqrt{\quad}$	$\sqrt[3]{\quad}$	=	(.)	%
🗑️	▼					

Part B

Circle Q , defined by the equation $x^2 + y^2 = 16$, is graphed in the same coordinate plane as circle P .

Select from the drop-down menus to correctly complete each statement.

The center for circle Q is and to the of the center of circle P .

above
below

left
right

The radius of circle Q is the radius of circle P .

less than
greater than

11.

VF622885

The figure shows a circle with chord \overline{BD} through center O . The measure of $\angle AOD$ is 50° .

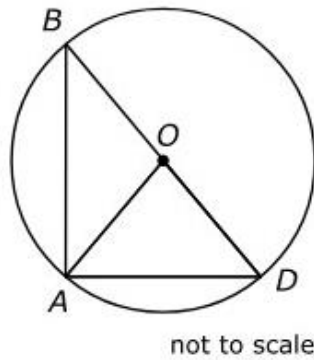

Part A

Which angles must have a measure of 25° ?

Select **all** that apply.

- A. $\angle BAD$
- B. $\angle ABD$
- C. $\angle BAO$
- D. $\angle DAO$
- E. $\angle ADB$

Part B

For each triangle in the table, use the information given in the figure to identify if the triangle must be isosceles or must be right.

Select the correct box on each row.

Triangle	Must Be Isosceles	Must Be Right
$\triangle ABD$	<input type="checkbox"/>	<input type="checkbox"/>
$\triangle AOD$	<input type="checkbox"/>	<input type="checkbox"/>
$\triangle ABO$	<input type="checkbox"/>	<input type="checkbox"/>

12.

VH003665

According to the Occupational Safety and Health Administration, a ladder should be positioned at an angle such that the distance from the bottom of the ladder to the wall it is leaning against is no more than $\frac{1}{4}$ of the length of the ladder.

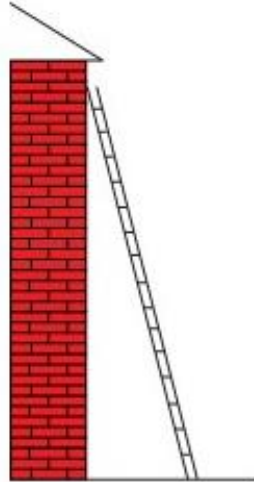

Part A

If a 30-foot ladder is positioned so that the bottom of the ladder is $\frac{1}{4}$ of its length away from the wall, how far up the wall will it reach? Round to the nearest foot.

Enter your answer in the box.

Part B

If a 30-foot ladder is positioned so that the bottom of the ladder is $\frac{1}{4}$ of its length away from the wall, what angle does the ladder make with the ground? Round your answer to the nearest degree.

Enter your answer in the box.

(continues on next page)

12. (continued from previous page)

VH003665

Part C

The bottom of Sam's 30-foot ladder is 6 feet from the base of the wall it is leaning against. If Sam moves the bottom of the ladder 1 foot farther away from the wall, which of the listed statements is true?

- A. The top of the ladder will move down by about 0.22 foot.
- B. The top of the ladder will move down by about 1.0 foot.
- C. The top of the ladder will move up by about 1.22 feet.
- D. The top of the ladder will not move.

Part D

The bottom of Sam's 30-foot ladder is 6 feet from the base of the wall it is leaning against. If Sam moves the bottom of the ladder 1 foot farther away from the wall, which of the listed statements is true?

- A. The angle the ladder makes with the ground will increase by about 3 degrees.
- B. The angle the ladder makes with the ground will decrease by about 1 degree.
- C. The angle the ladder makes with the ground will decrease by about 2 degrees.
- D. The angle the ladder makes with the ground will not change.

13.

M46629

A repairman plans to rent a bucket truck to repair the roof of a building. The diagram shows a bucket truck and the building.

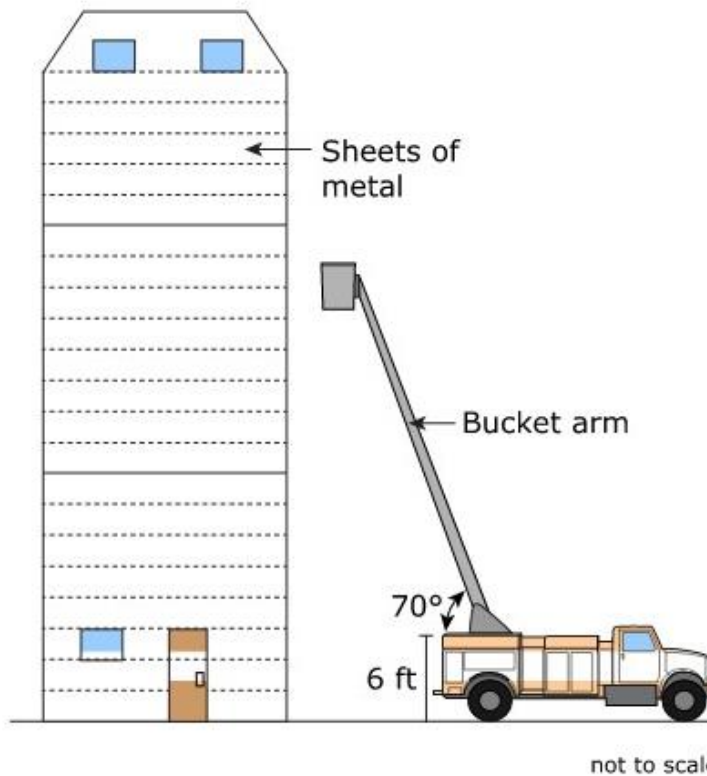

The door of the building is 7.5 feet tall. Sheets of metal are horizontally placed on the outside of the building. The sheets of metal are equally placed from the bottom to the top of the building. A bucket truck's arm is 6 feet off the ground and its maximum angle is 70° .

- What is a best estimate for the height of this building? Explain your reasoning and any assumptions made.
- What is the minimum bucket arm length the repairman needs to rent to reach the roof? Round your answer to the nearest foot. Explain your answer or show your work.

Enter your answers and work or explanations in the space provided.



- ▶ Math symbols
- ▶ Relations
- ▶ Geometry
- ▶ Groups
- ▶ Trigonometry
- ▶ Statistics
- ▶ Greek

14.

VH127150

A 225-foot support wire is attached to the top of a monument at a stake on the ground 100 feet from the base of the monument, as shown.

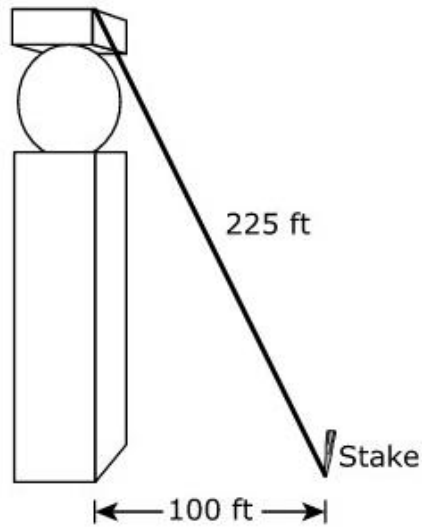

Part A

What is the approximate height of the monument?

- A. 125 feet
- B. 202 feet
- C. 246 feet
- D. 325 feet

Part B

What is the angle of elevation from the stake on the ground to the top of the monument?

- A. 24.0°
- B. 26.4°
- C. 63.6°
- D. 66.0°

15.

VH124818

The image shown will undergo a dilation centered at point B , with a scale factor of 2.

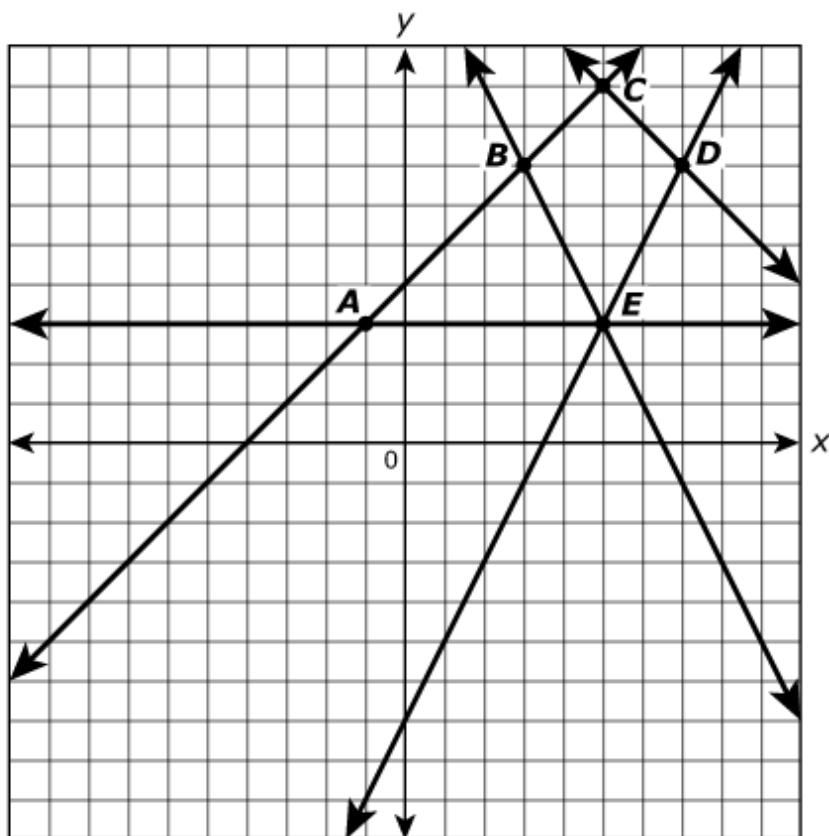

Which lines will **not** be changed by the transformation?

Select **all** that apply.

- A. \overleftrightarrow{AC}
- B. \overleftrightarrow{AE}
- C. \overleftrightarrow{BE}
- D. \overleftrightarrow{CD}
- E. \overleftrightarrow{DE}

16.

M47349

A company is designing a circular logo for a product. The inner part of the logo is a circle with a radius of r inches. The logo has a border that is a concentric circle surrounding the inner circle. The area of the border is 14.5 square inches. The logo is shown.

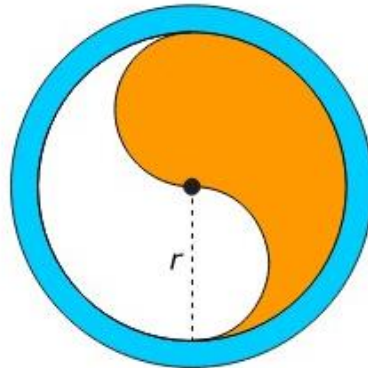

Write an expression that represents the total area, in square inches, of the logo in terms of the radius, r , of the inner part of the logo. If the total area of the logo is 127 square inches, what is the approximate value of r ? Show your work or explain your answer.

Enter your expression, your answer, and your work or explanation in the space provided.



- [▶ Math symbols](#)
- [▶ Relations](#)
- [▶ Geometry](#)
- [▶ Groups](#)
- [▶ Trigonometry](#)
- [▶ Statistics](#)
- [▶ Greek](#)

17.

VH230374

The graph of line p with the equation $3x + 2y = 12$ is shown in the coordinate plane. Line m is the image of line p after a dilation with center at the origin and a scale factor of 2.

Graph line m by selecting two points on the coordinate plane. A line will be drawn through the points.

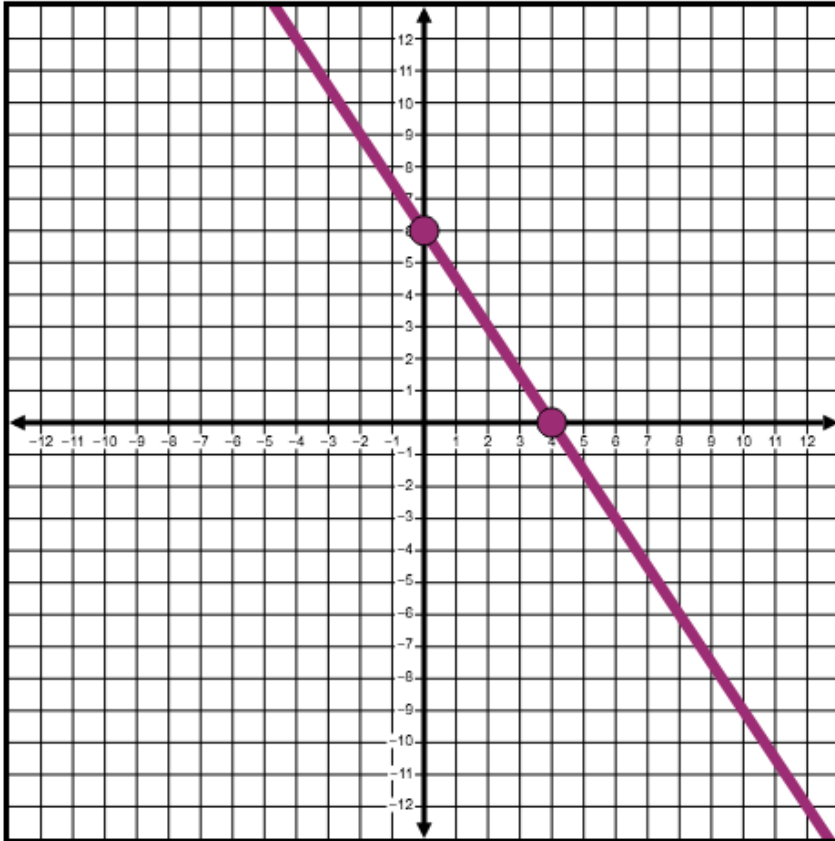

18.

VH224535

Segment JL has endpoints $J(-3, -4)$ and $L(7, 6)$. Place point K on the coordinate plane so that point K is on \overline{JL} and $JK = \frac{3}{5}JL$.

Select the place on the coordinate plane to plot the point.

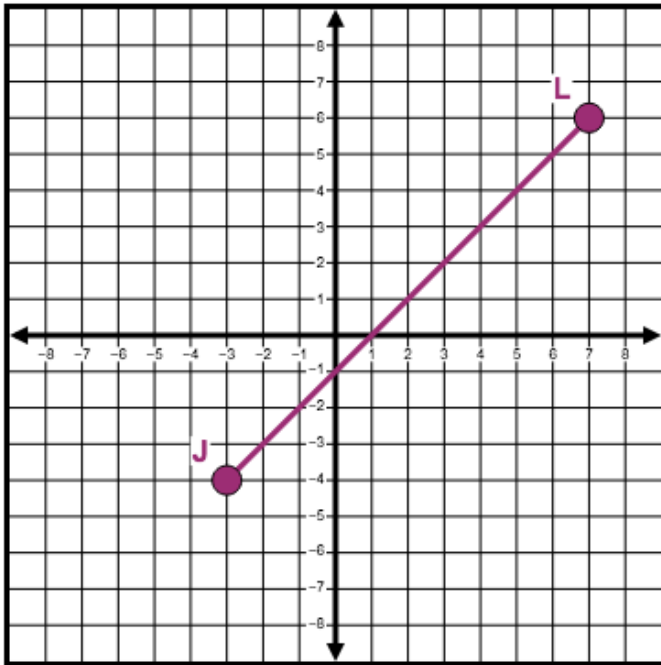

19.

VH128841

A student stands 50 feet away from the front of a building and measures the angle of elevation to the top of the building. From the student's eye level 5 feet off the ground, the angle of elevation to the top of the building is 30° . Approximately what is the height of the building?

- A. 25 feet
- B. 29 feet
- C. 30 feet
- D. 34 feet

20.

VF891333

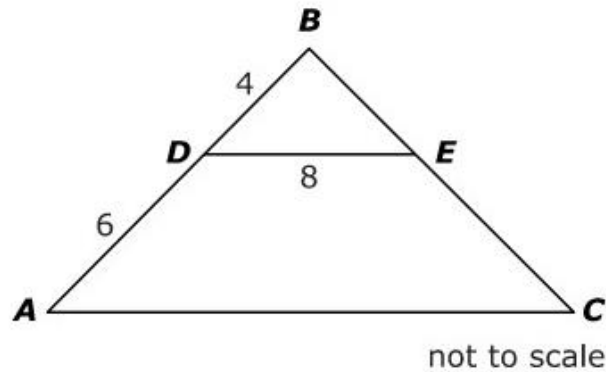

In triangle ABC shown, $\overline{DE} \parallel \overline{AC}$. What is the length of \overline{AC} ?

Enter your answer in the box.

21.

VH244003

Given: Quadrilateral $PQRS$ on the coordinate plane.

- Quadrilateral $P'Q'R'S'$ is the image of quadrilateral $PQRS$ after a single transformation.
- Quadrilateral $P''Q''R''S''$ is the image of quadrilateral $P'Q'R'S'$ after a single transformation.

Which statement is true?

Select **all** that apply.

- A. If $P'Q'R'S'$ is formed by translating $PQRS$ 4 units to the right and 5 units down, then $PQRS \cong P'Q'R'S'$.
- B. If $P'Q'R'S'$ is formed by dilating $PQRS$ with scale factor $\frac{2}{5}$ and center P , then $PQRS \cong P'Q'R'S'$.
- C. If $P'Q'R'S'$ is formed by rotating $PQRS$ 60° clockwise about the origin, then $PQRS \cong P'Q'R'S'$.
- D. If $P'Q'R'S'$ is formed by rotating $PQRS$ 90° clockwise about point Q and $P''Q''R''S''$ is formed by dilating $P'Q'R'S'$ with scale factor $\frac{1}{2}$ and center R , then $PQRS \cong P''Q''R''S''$.
- E. If $P'Q'R'S'$ is formed by dilating $PQRS$ with scale factor $\frac{3}{4}$ and center S and $P''Q''R''S''$ is formed by dilating $P'Q'R'S'$ with scale factor $\frac{4}{3}$ and center S' , then $PQRS \cong P''Q''R''S''$.

22.

VH184676

In the coordinate plane, quadrilateral $ABCD$ has vertices $A(-2, 3)$, $B(4, 5)$, $C(10, -1)$, and $D(8, -9)$. Let E , F , G , and H be the midpoints of \overline{AB} , \overline{BC} , \overline{CD} , and \overline{DA} , respectively.

Prove that quadrilateral $EFGH$ is a parallelogram.

Enter your proof in the space provided.



-
-
-
-
-
-
-

Three pairs of figures are shown in the xy -coordinate plane.

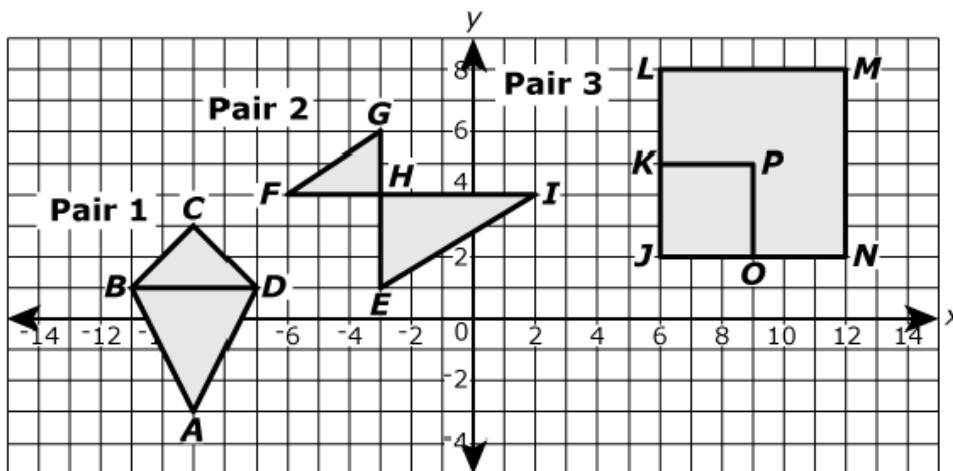

Select from the drop-down menus to correctly complete each sentence.

The figures in pair 1 similar because

 are
 are not

Triangle ABD is the image of Triangle CBD after a reflection followed by dilation
 Triangle ABD is the image of Triangle CBD after a rotation followed by dilation
 Triangle ABD is not the image of Triangle CBD after any sequence of similarity transformations

The figures in pair 2 similar because

 are
 are not

Triangle EHI is the image of Triangle GHF after a reflection followed by a dilation
 Triangle EHI is the image of Triangle GHF after a rotation followed by a dilation
 Triangle EHI is not the image of Triangle GHF after any sequence of similarity transformations

The figures in pair 3 similar because

 are
 are not

JKPO is the image of JLMN after a dilation
 JKPO is the image of JLMN after a reflection followed by a rotation
 JKPO is not the image of JLMN after any sequence of similarity transformations

24.

M43647

The figure shows right triangles drawn inside of a rectangle.

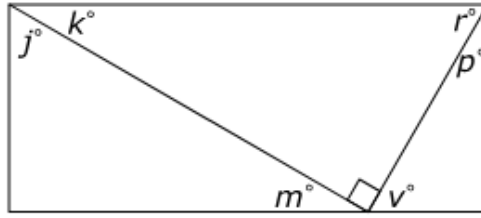

Select from the drop-down menus to correctly complete each statement.

$\sin p^\circ = \cos$ $^\circ$

j
k
m

$\cos k^\circ = \sin$ $^\circ$

m
p
v

25.

VF885353

The animation shows the construction of a line parallel to a given line through a given point not on the line.

To pause the animation, select the animation window.

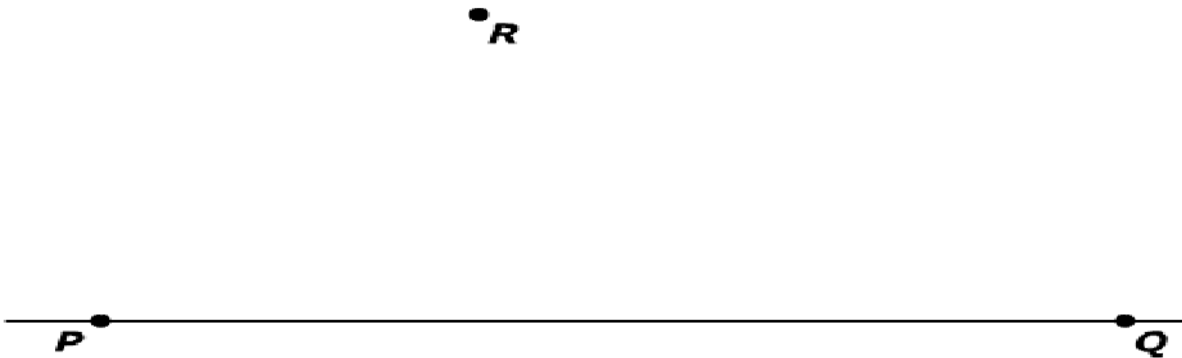

Part A

Select from the drop-down menu to correctly complete the sentence.

The construction is creating an angle congruent to

- Choose...
- Choose...
- $\angle PJR$
- $\angle RJQ$
- $\angle JRS$
- $\angle RSQ$

Part B

What is the justification for proving that the constructed line is parallel to the given line?

- A. If two parallel lines are cut by a transversal, then alternate interior angles are equal.
- B. If two parallel lines are cut by a transversal, then same-side interior angles are supplementary.
- C. If two lines cut by a transversal form congruent corresponding angles, then the lines are parallel.
- D. If two lines cut by a transversal form congruent alternate interior angles, then the lines are parallel.

26.

VF671199

Use the figure to complete the proof to establish part of this theorem: If a point is equidistant from the endpoints of a segment, then it is on the perpendicular bisector of the segment.

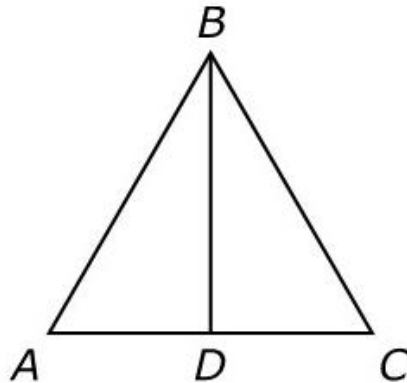

Given: $AB = CB$; D is the midpoint of \overline{AC} .

Prove: $\overline{AC} \perp \overline{BD}$

Enter your proof in the space provided.



- ▶ Math symbols
- ▶ Relations
- ▶ Geometry
- ▶ Groups
- ▶ Trigonometry
- ▶ Statistics
- ▶ Greek

27.

M100341

The table shows several characteristics of two United States coins.

Characteristics of Two United States Coins

	Penny	Presidential Dollar
Diameter (mm)	19.05	26.49
Height (mm)	1.55	2.00
Copper	2.5%	88.5%
Zinc	97.5%	6%
Nickel	-	2%

Part A

US coins are roughly in the shape of cylinders. Therefore, the formula for the volume of a cylinder can be used to compare the volumes of coins. How does the combined volume of 3 pennies compare to the volume of 1 presidential dollar?

Select from the drop-down menus to correctly complete the sentence.

The volume of 3 pennies is than the volume of 1 presidential dollar by approximately cubic millimeters.

less
greater

Choose...
223.1
660.5
2,260.5

(continues on next page)

27. (continued from previous page)

M100341

Part B

One hundred presidential dollars will be put into 4 stacks of 25 dollars each for shipment. The stacks can be arranged in two different ways to be boxed, as shown. Cardboard will be used to box the stacks on all sides with no overlap.

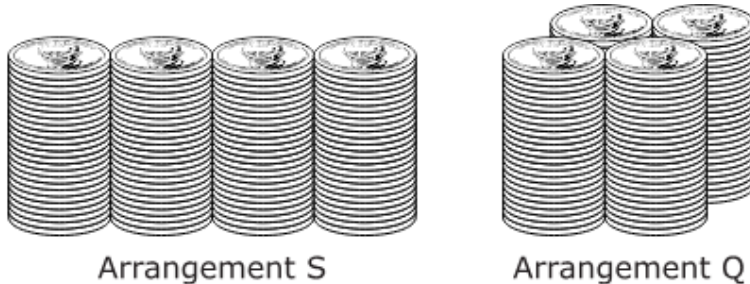

How does the amount of cardboard used to construct the two boxes compare? How do the volumes of the two boxes compare?

Select from the drop-down menus to correctly complete the sentences.

The amount of cardboard needed to make the box for Arrangement S is

Choose... amount of cardboard needed for Arrangement Q.

Choose...
less than the
greater than the
the same

The volume of Box S is

Choose... the volume of Box Q.

Choose...
less than the
greater than the
the same

Part C

The density of copper is about 0.0089 gram per cubic millimeter. The density of zinc is about 0.00714 gram per cubic millimeter.

Based on the percentages provided in the table, what is the density, in grams per cubic millimeter, of a United States penny?

- A. 0.0072
- B. 0.0075
- C. 0.0078
- D. 0.0080

(continues on next page)

27. (continued from previous page)**M100341****Part D**

In March 2015, the price of copper was approximately \$0.006 per gram. If the mass of a penny is 2.59 grams, what is the cost, in dollars, of the copper content of 1 penny?

- A. \$0.004
- B. \$0.006
- C. \$0.0004
- D. \$0.0006

28.**VH204994**

The sector of a circle has an area of $\frac{104\pi}{9}$ square inches and a central angle with measure 65° . What is the radius of the circle, in inches?

- A. 5.7
- B. 8
- C. 64
- D. 104

29.**M45113P**

The point $(3, -6)$ is an endpoint to a diameter of circle P . The equation $x^2 + y^2 - 6x + 2y = 15$ represents circle P . What is the y -coordinate of the other endpoint of this diameter?

- A. -11
- B. -1
- C. 4
- D. 5

30.

M43437

The figure shows right triangle MPR on the coordinate plane. Line segment MQ is a median of the triangle.

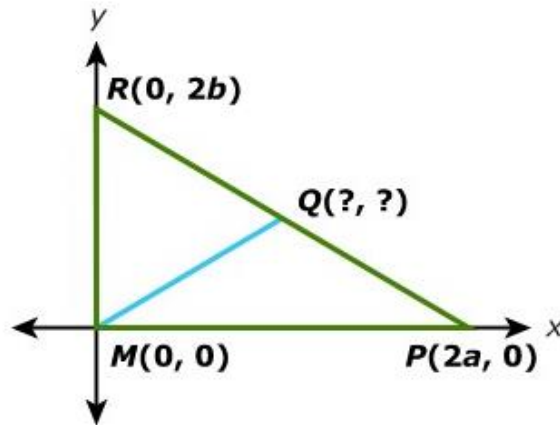

What are the coordinates of point Q ? Explain your answer. Using the information in the figure, show that the length of the median \overline{MQ} is half the length of the hypotenuse of $\triangle MRP$. Provide an argument supported by valid mathematical reasoning and/or calculations.

Enter your answer and your reasoning in the space provided.



- ▶ Math symbols
- ▶ Relations
- ▶ Geometry
- ▶ Groups
- ▶ Trigonometry
- ▶ Statistics
- ▶ Greek

31.

2130-M40821

Sam has proposed a design for his company's trucks.

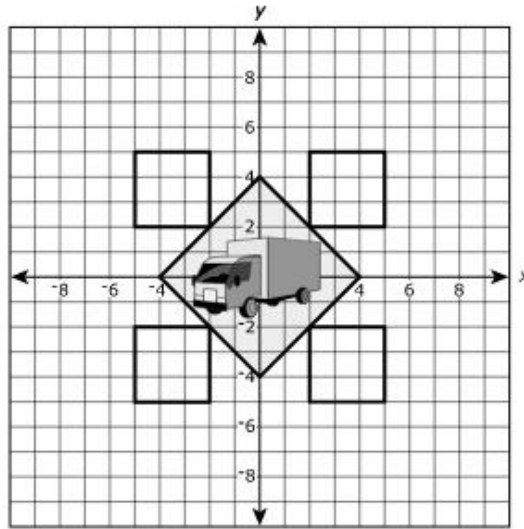

Part A

What is the sum of the perimeters, in units, of the five squares in the design? Round your answer to the nearest tenth.

Enter your answer in the box.

Part B

What is the sum of the areas, in square units, of the five squares in the design? Round your answer to the nearest whole unit.

Enter your answer in the box.